

Cuatura Centro Dietro ~ Drittofilo

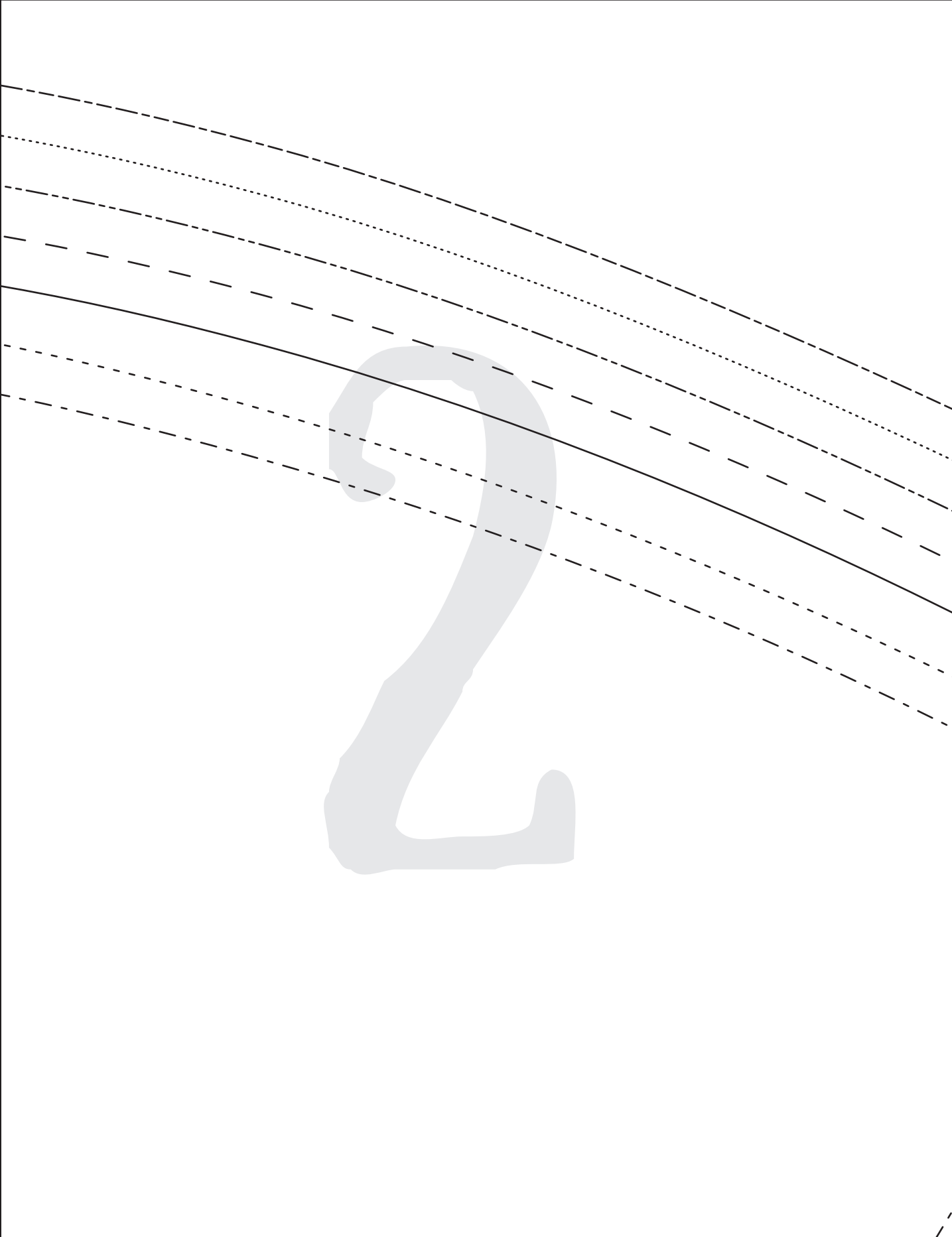

1A

1B

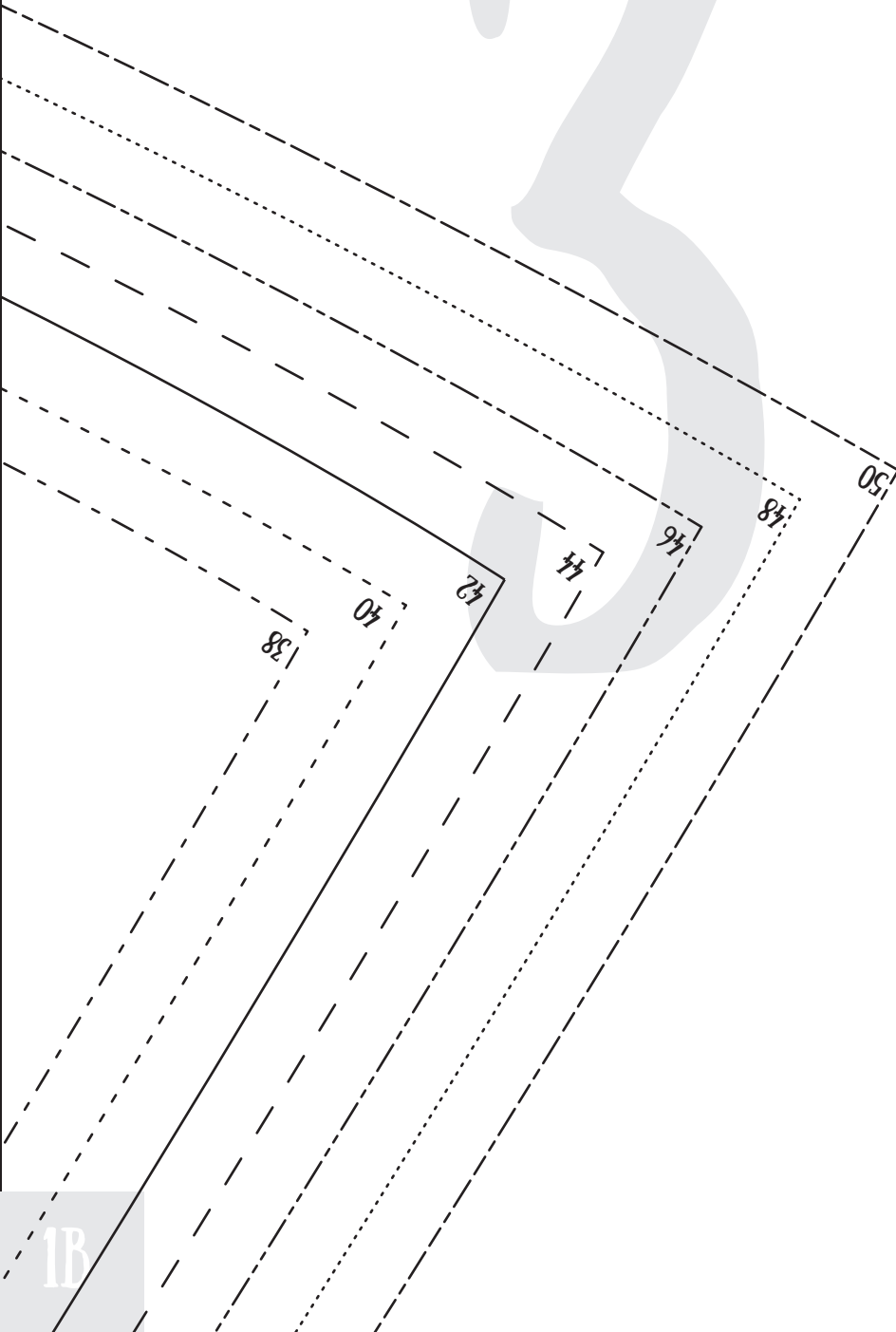
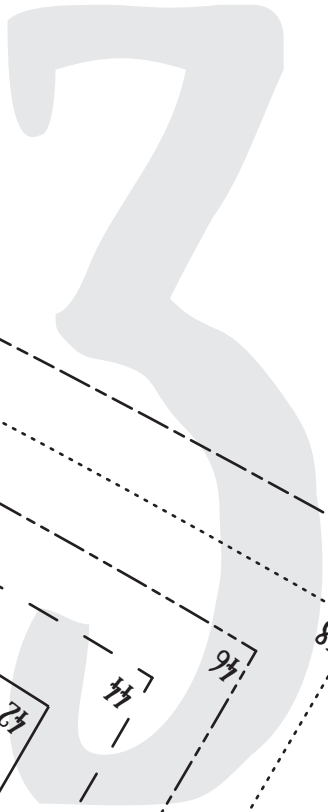

1B

1C

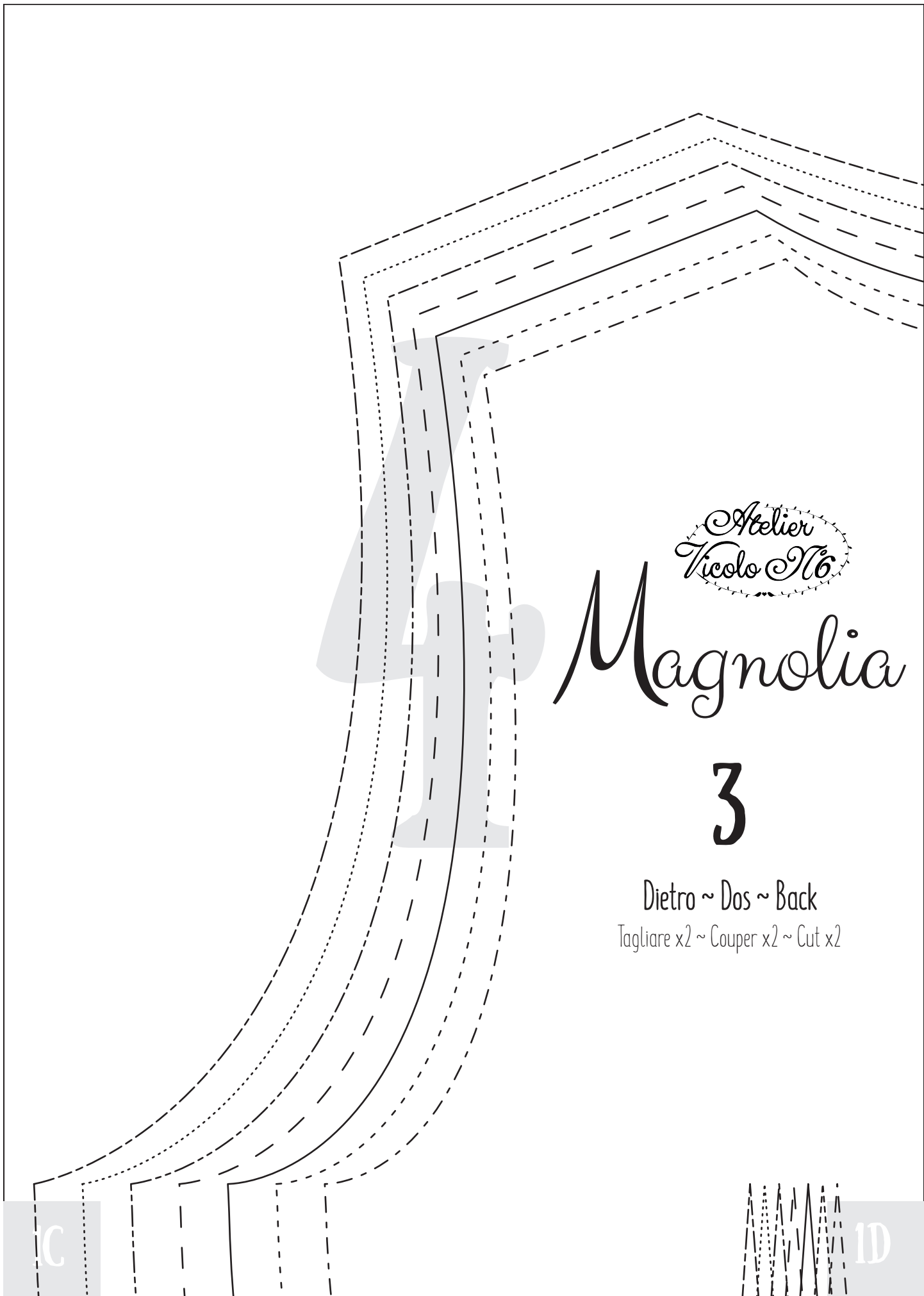

Atelier  
Ticolo N°6

# Magnolia

## 3

Dietro ~ Dos ~ Back  
Tagliare x2 ~ Couper x2 ~ Cut x2

C

D

Couture Milieu Dos ~ Droit Fil    Center Back ~ Grainline

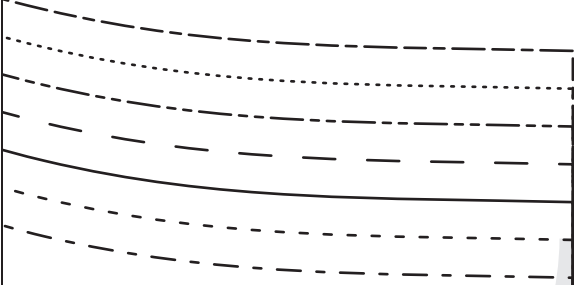
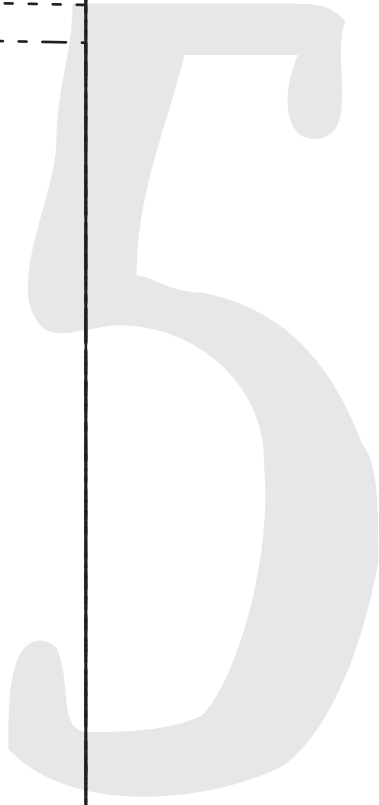

40	42	44	46	48	50
----	----	----	----	----	----

Gonna Dietro ~ Jupe Dos ~ Back Skirt  
Tagliare x2 ~ Couper x2 ~ Cut x2

7

Magnolia



Couture Milieu Dos ~ Droit Fil Center Back ~ Grainline

1A

1B

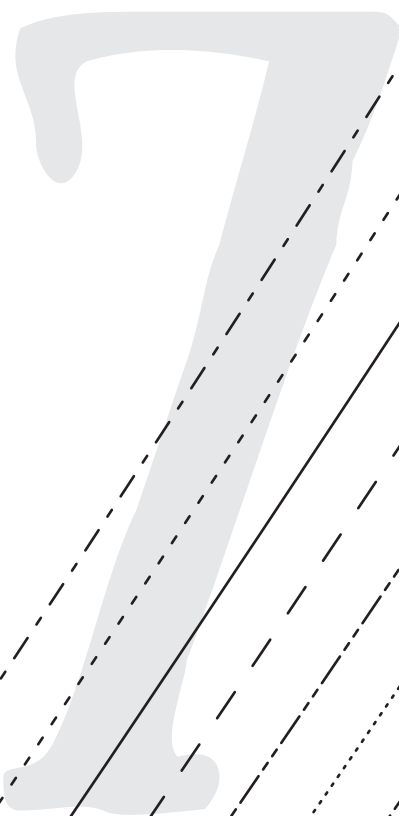

2A

2B

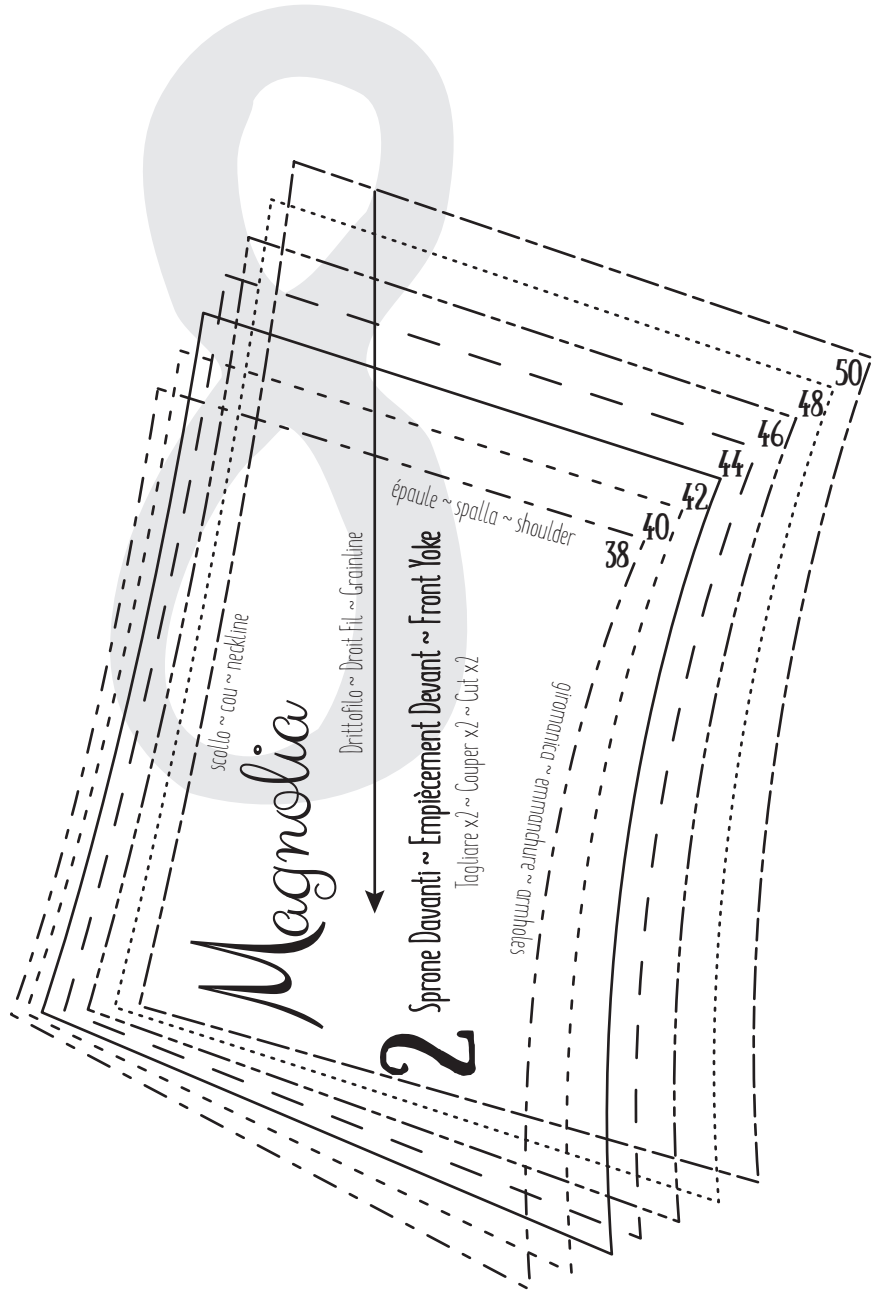



1C

1D

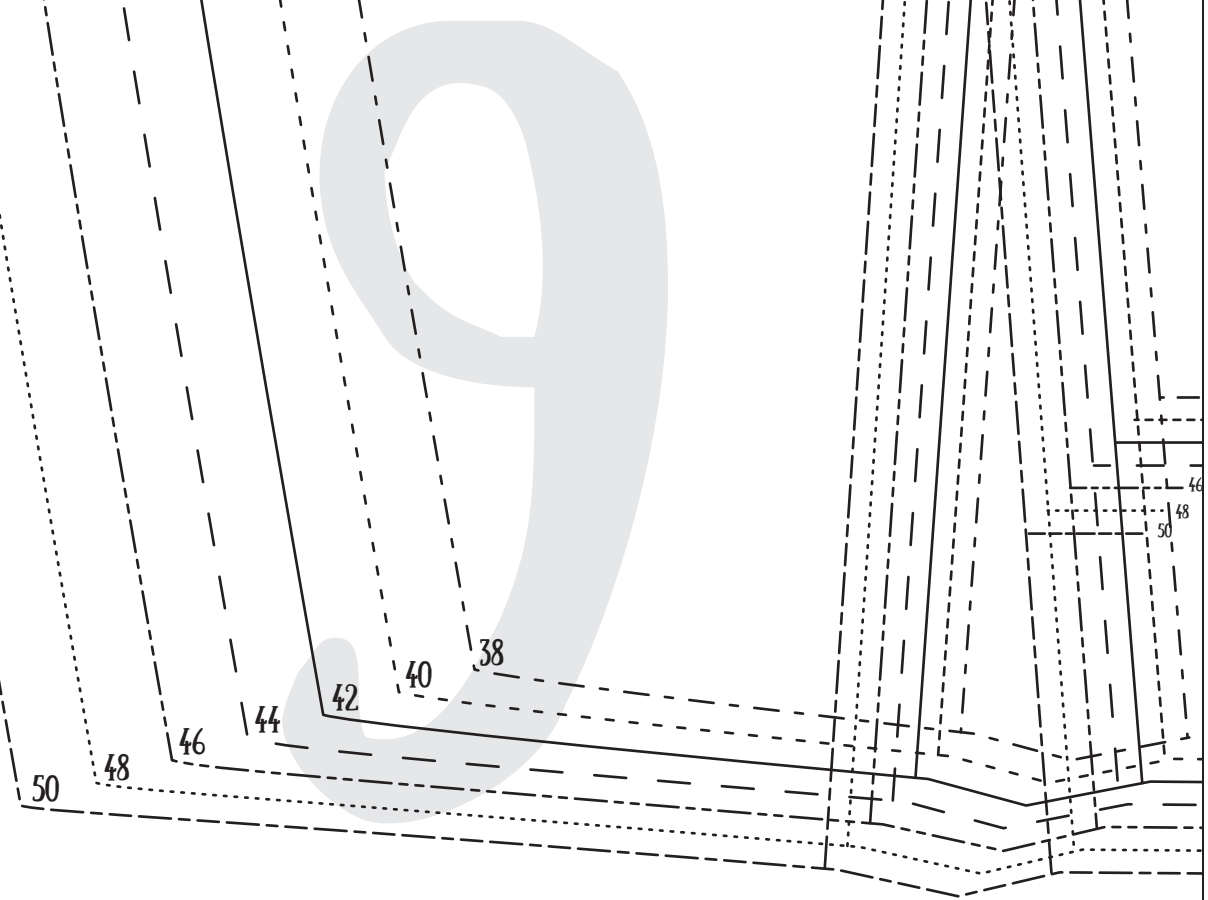

<p><i>Atelier Ticolo N°6</i></p> <p>Linea piega ~ ligne de pliure ~ Fold line</p>	<p>9</p>
<p><i>Magnolia</i></p>	<p>Passanti ~ Passant ~ Belt Loop Tagliare x2 ~ Couper x2 ~ Cut x2</p>

2C

2D

1D

Cucitura Centro Dietro ~ Drittofilo

38  
40  
42  
44  
Posizione passanti ~ Position Passant ~ Belt Loops Position

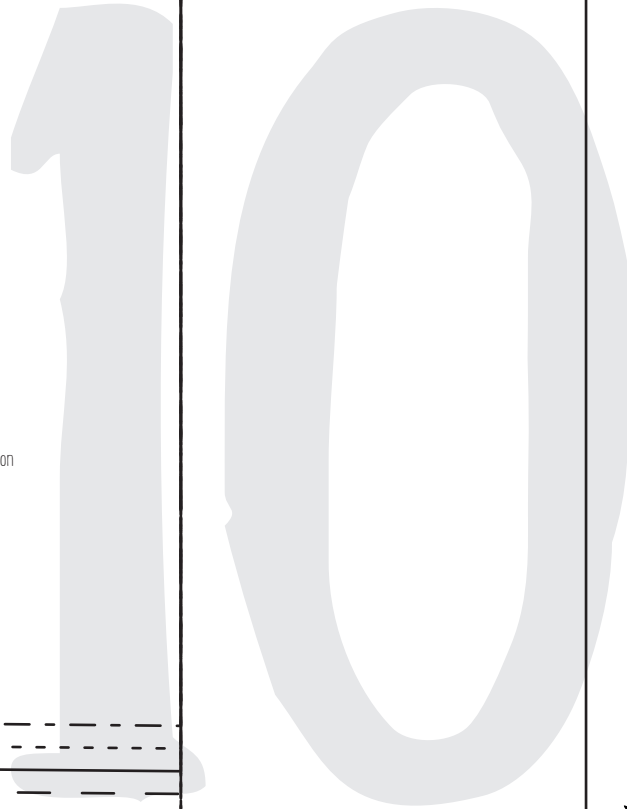

Atelier  
Ticolo No. 9

Linea piega ~ ligne de pliure ~ Fold line

Magnolia Passanti ~ Passant ~ Belt Loop  
Tagliare x2 ~ Couper x2 ~ Cut x2

2D

Cintura ~ Ceinture ~ Belt  
Tagliare x2 ~ Couper x2 ~ Cut x2

8

Atelier  
Ticolo No. 8  
Magnolia

38

2A

Posizione passanti ~ Belt Loops Position

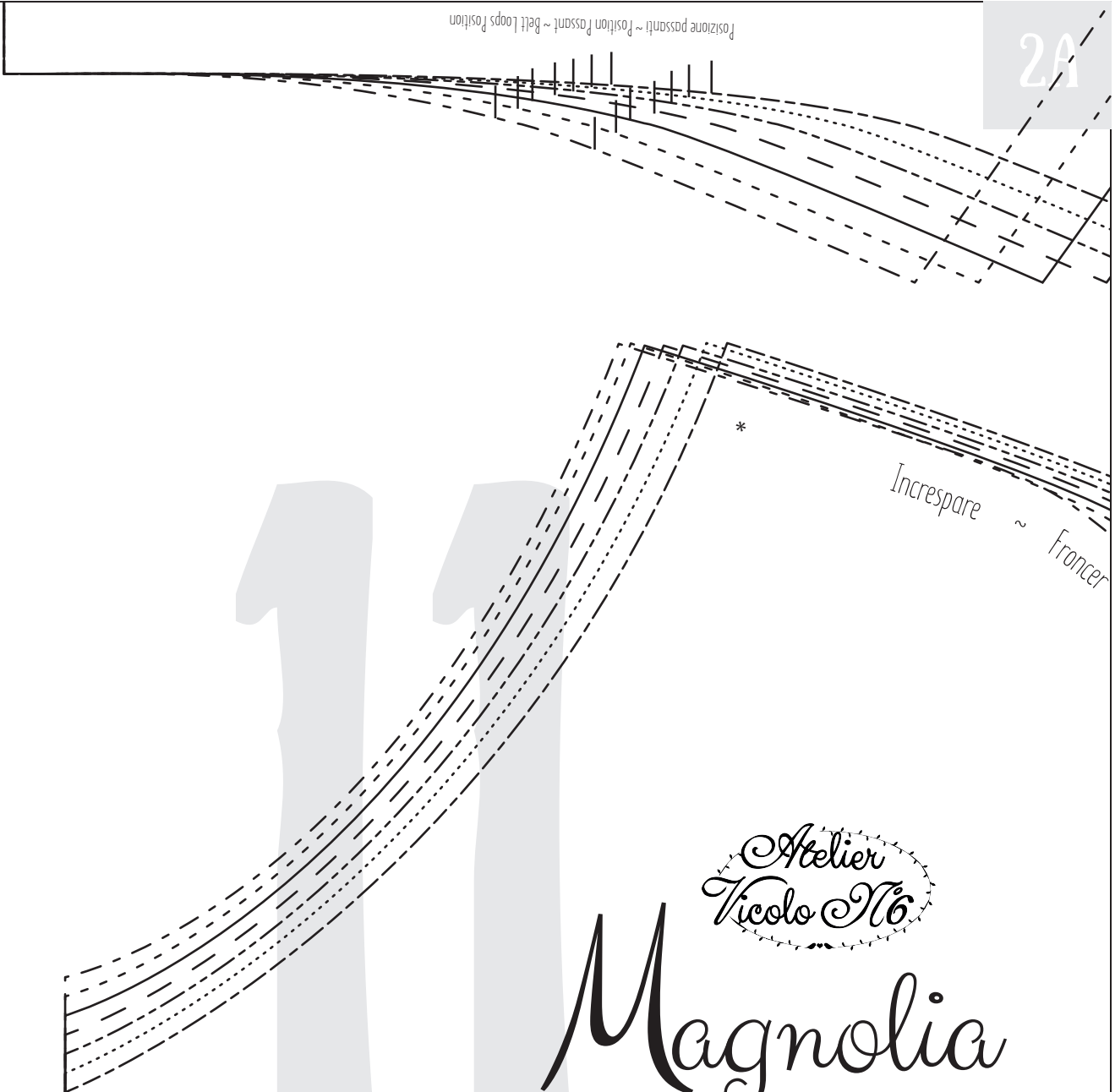

Increase ~ Froncer

Atelier  
Vicolo N°6

# Magnolia

## 1

Davanti ~ Devant ~ Front

Tagliare x1 in doppio ~ Couper x1 sur pliure ~ Cut x1 on fold

ure ~ Droit Fil    Center Front on fold ~ Grainline



3A

2A

2B

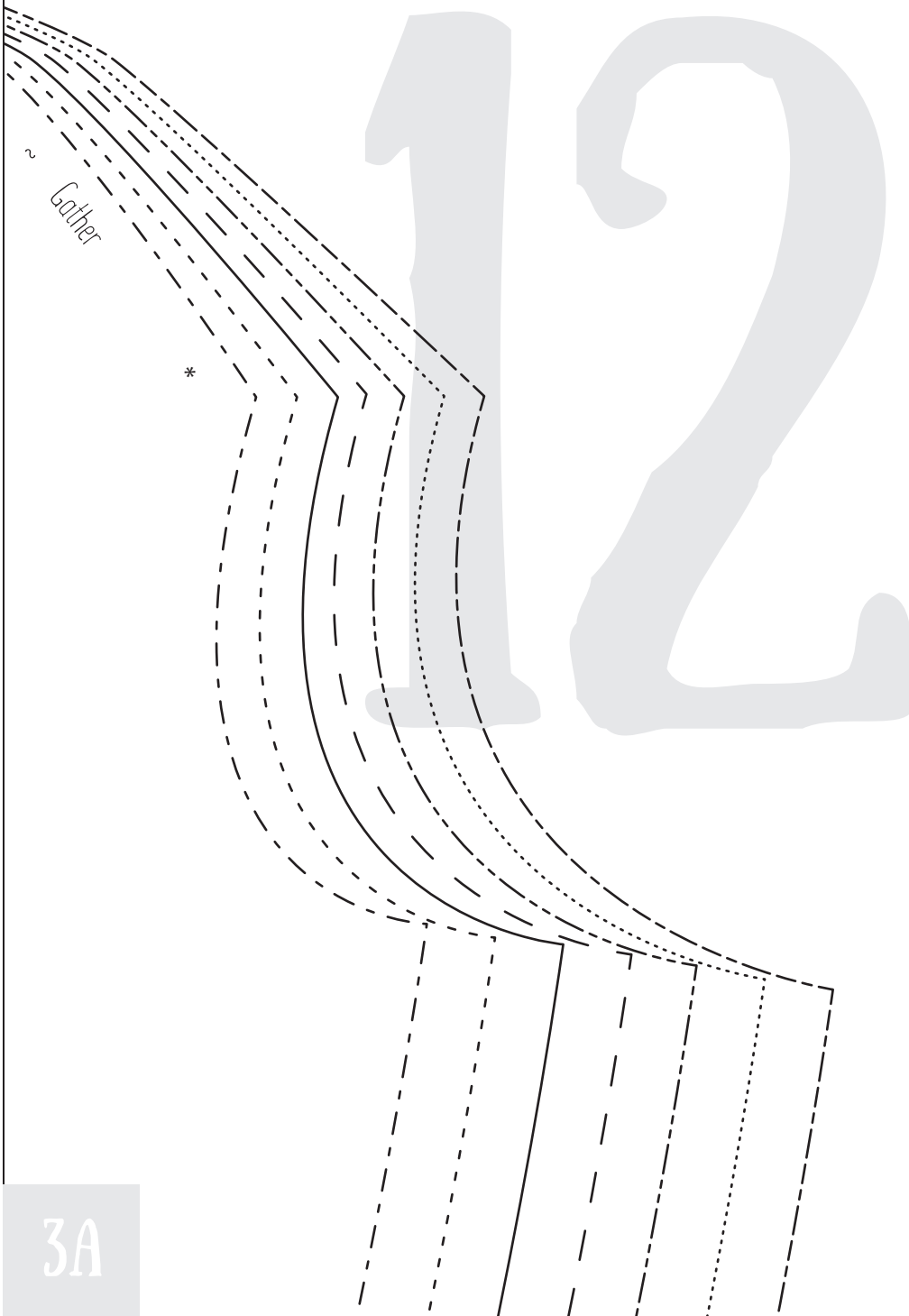

3A

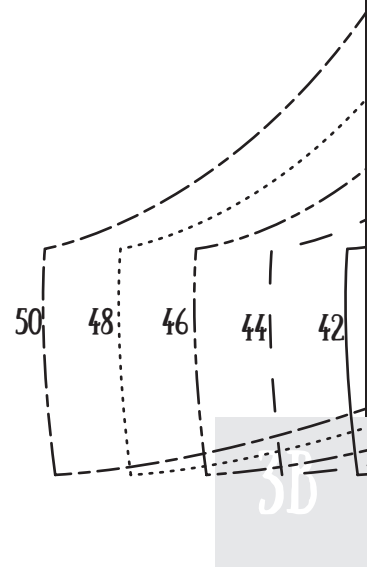

2B

2C

Atelier  
Ticolo N°6

Magnolia

5

Paramontura Dietro ~ Parementure Dos ~ Back Facing

Tagliare x2 ~ Couper x2 ~ Cut x2

40 38

3D

3C

2C

2D

Cucitura Centro Dietro ~ Drittofilo  
Couture Milieu Dos ~ Droit Fil  
Center Back ~ Grainline

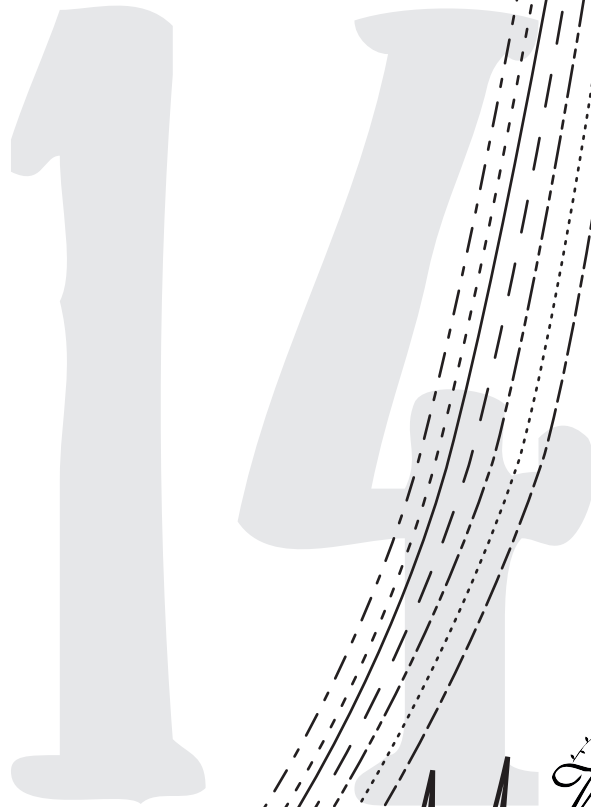

Atelier  
Ticolo No. 6

Magnolia

4

Paramontura Davanti ~ Parementure Devant ~ Front Facing

Tagliare x1 in doppio ~ Couper x1 sur pliure ~ Cut x1 on fold

3C

3D

in doppio  
lo  
sur pliure  
il  
on fold  
ne

2D

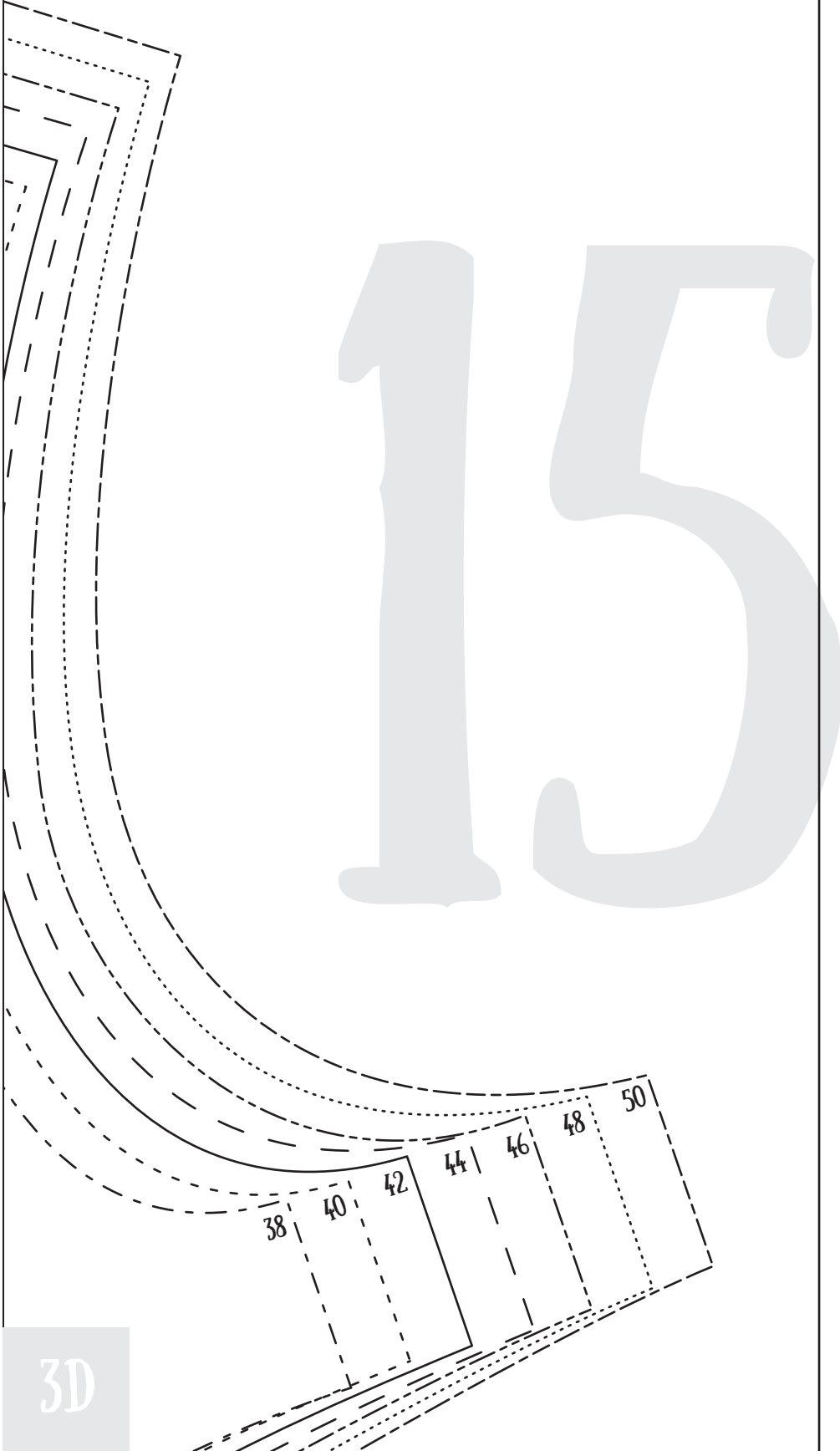

3D

Drittofilo ~ Droit Fil ~ Grainline

← Centro davanti in doppio ~ Drittofilo Milieu Devant sur pl

Posizione passanti ~ Position Passant ~ Belt Loops Position

38  
40  
42  
44  
46  
48  
50

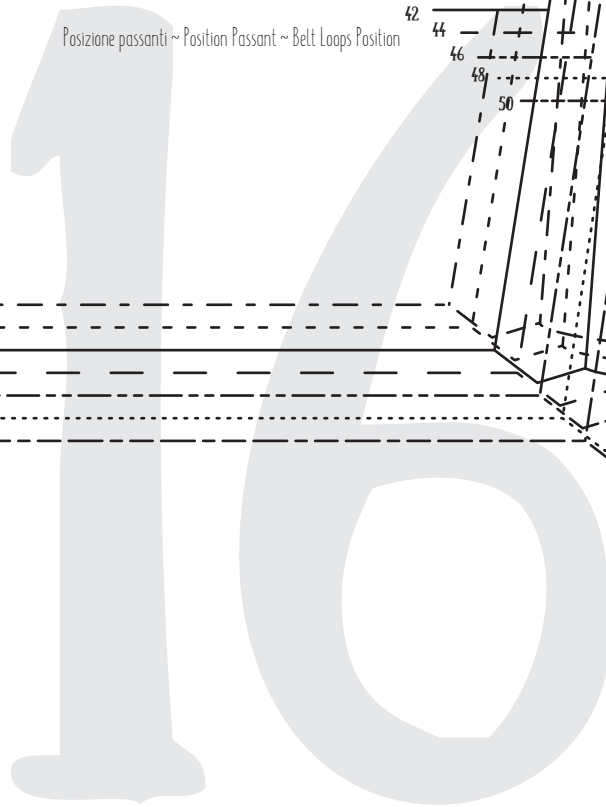



3A

3B

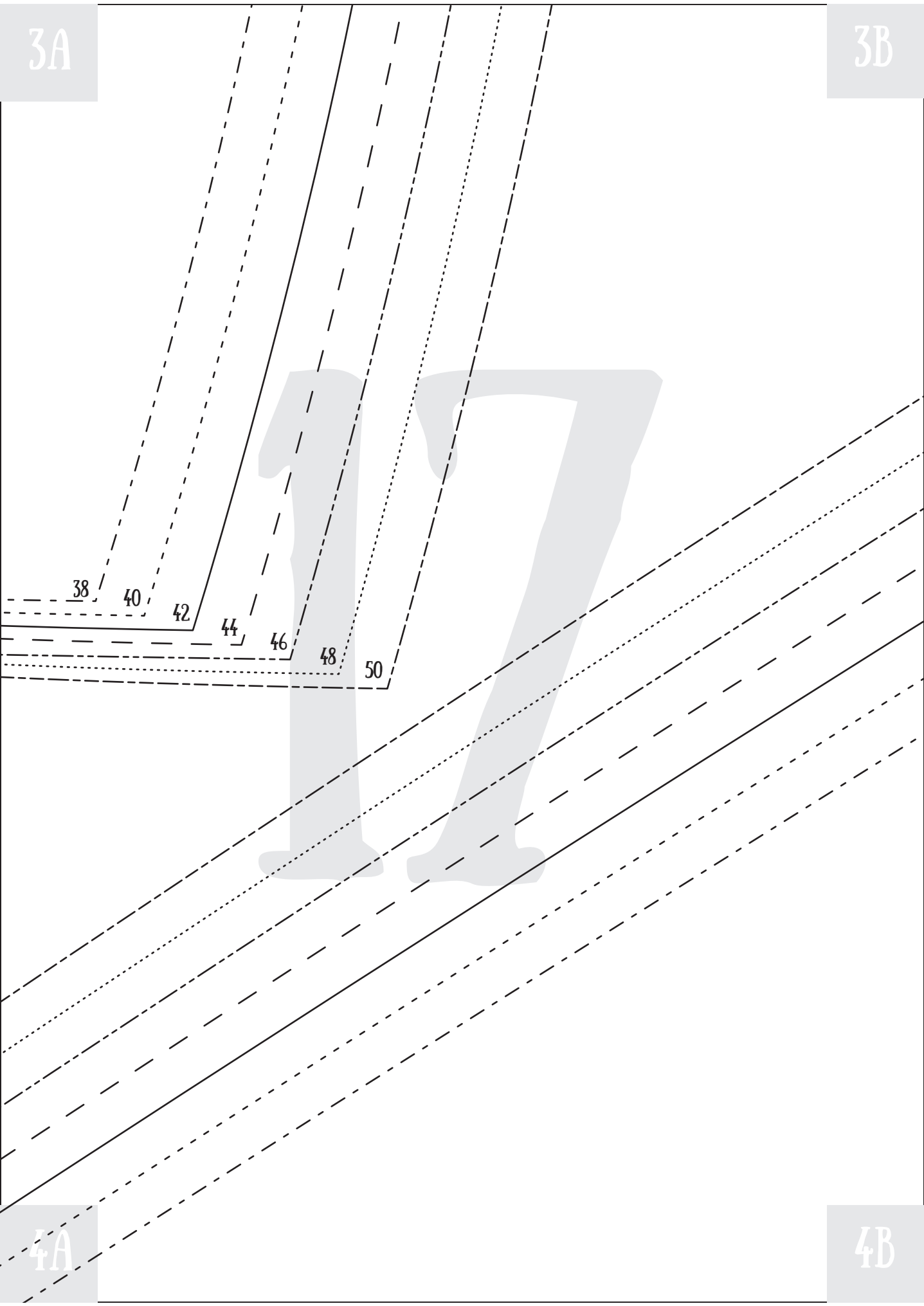

4A

4B

3B

3C

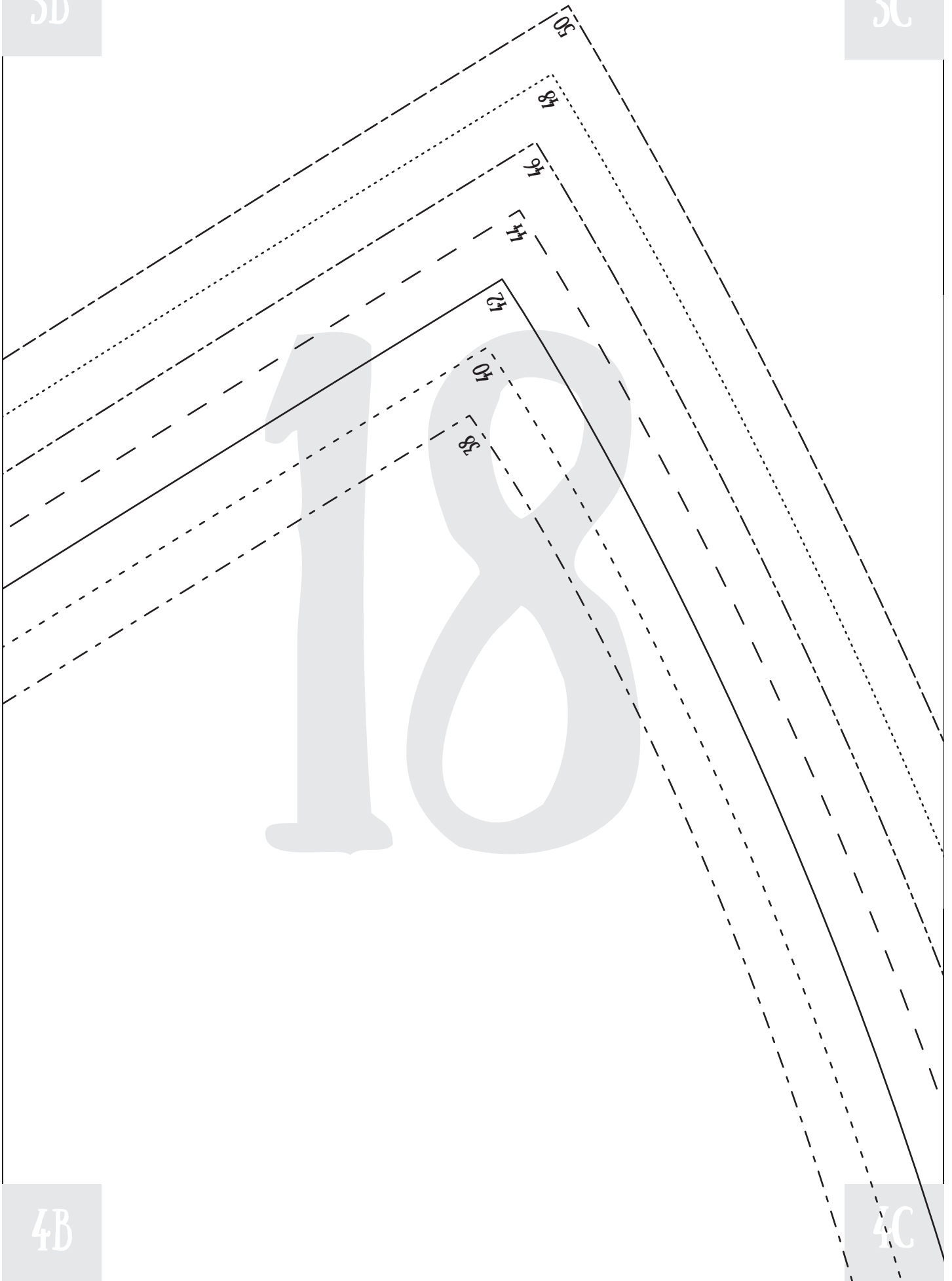

4B

4C

3C

3D

Centro davanti
Dritto
Milieu Devant
Droit
Center Front
Grants

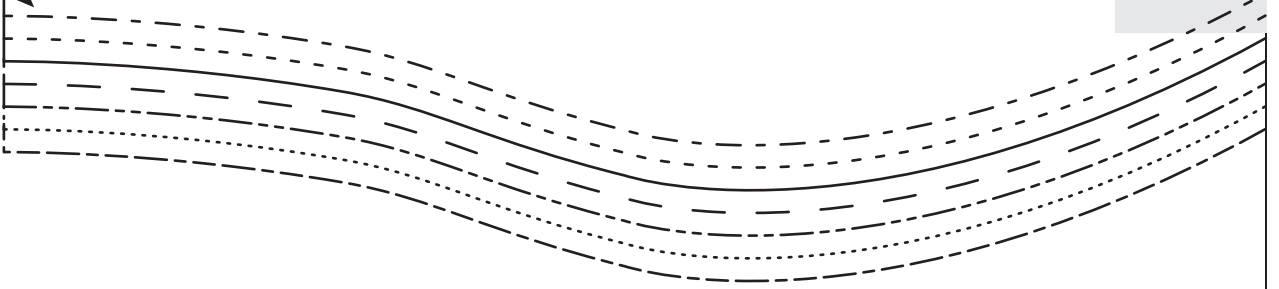

- |       |       |
|-------|-------|
| TG 38 | _____ |
| TG 40 | _____ |
| TG 42 | _____ |
| TG 44 | _____ |
| TG 46 | _____ |
| TG 48 | _____ |
| TG 50 | _____ |

4C

4D

# 20



Regolare in base alla Circonferenza Vita e alla Fibbia ~ Régler selon le Tour de Taille et le Boucle de la Ceinture ~ Set by your Waist Circumference and the Belt's Buckle

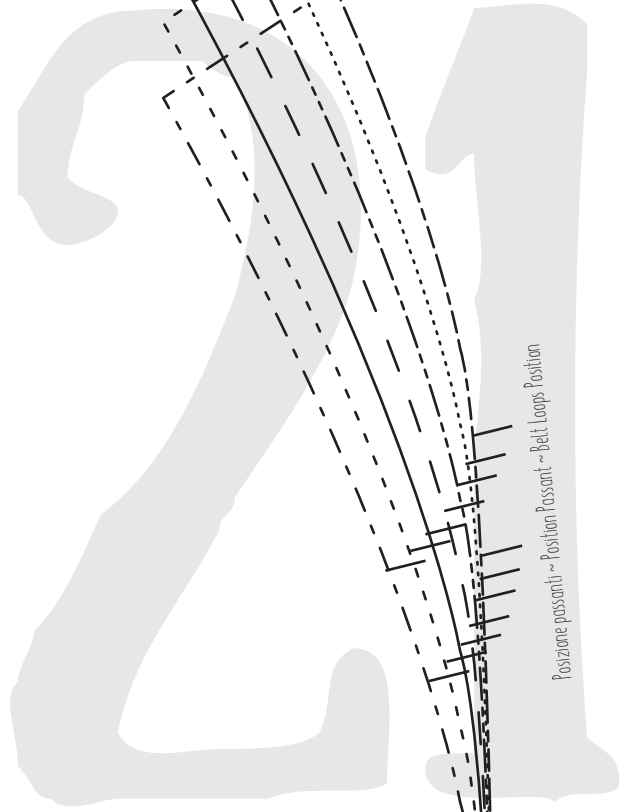

Posizione passanti ~ Position Passant ~ Belt Loops Position

Atelier  
Nicole N°6

# Magnolia

## 6

Gonna Davanti ~ Jupe Devant ~ Front Skirt

Tagliare x1 in doppio ~ Couper x1 sur pliure ~ Cut x1 on fold

↓ Centro Davanti in doppio ~ Drittofilo Milieu Devant sur pliure ~ Droit Fil. Center Front on fold ~ Grainline ↓

4B

4C

23

4C

4D

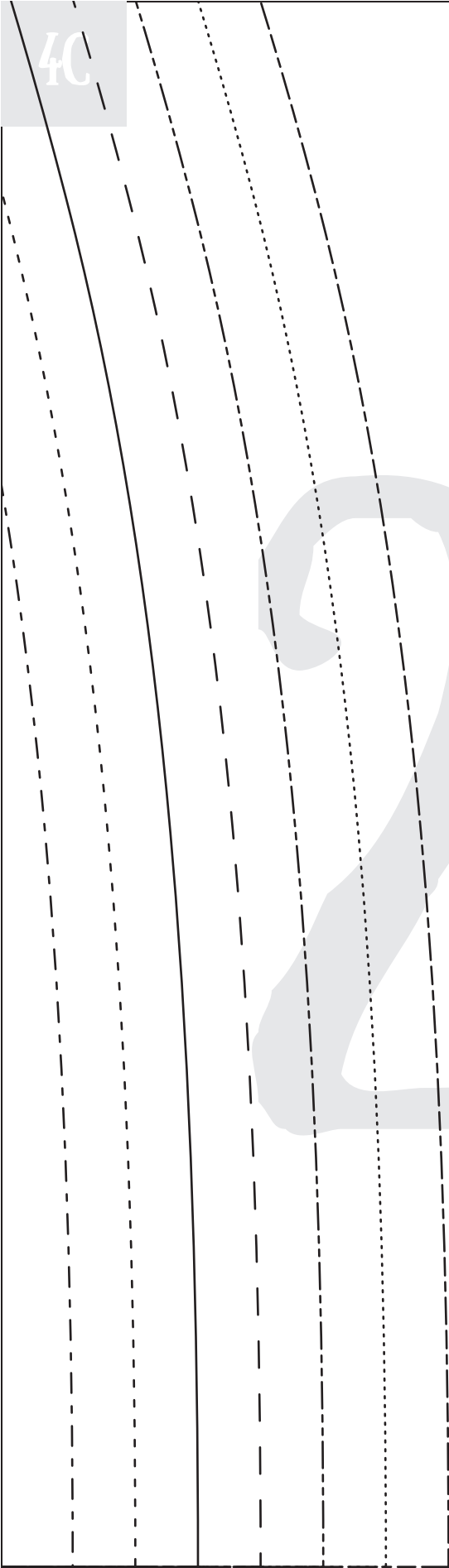
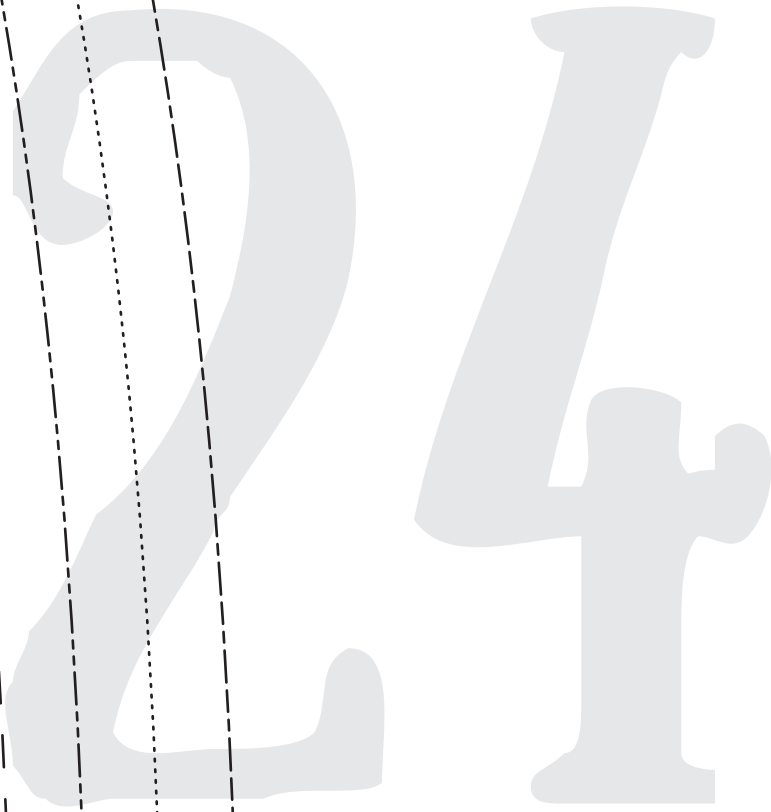



# Atelier Vicolo N°6

Condividete le vostre creazioni "Atelier Vicolo N°6" su Instagram e/o su Facebook con le Hashtags ~ Partagez vos réalisations "Atelier Vicolo N°6" sur Instagram et/ou sur Facebook avec les Hashtags ~ Share your creations "Atelier Vicolo N°6" on Instagram and Facebook with the Hashtags:

#ateliervicolon6  
#abitomagnolia #robemagnolia #magnoliadress  
#alltogetherpattern2



Questo cartamodello gratuito è riservato ad uso strettamente personale.  
Qualsiasi riproduzione o uso commerciale del cartamodello è proibita.

Ce patron gratuit est exclusivement destiné à un usage personnel.  
Toutes reproductions ou utilisations commerciales sont interdites.

This free pattern is for personal use only. Any commercial use of this pattern  
or realizations derived from it, is prohibited.